

# Linear conveyor HF

## Characteristics

Thanks to the compact design, the linear conveyor of type HF is especially well-suited for cramped spatial conditions. Linear conveyor sections up to a length of 350 mm

can be realized with the type HF. In addition, it offers optimal conditions for the use with vibration-sensitive transitions between the sorting device and linear rail. Thanks

to the direct screw connection, the rubber feet as well as the compensation weight aren't necessary as compared to the linear conveyor of type LF.

## Structure

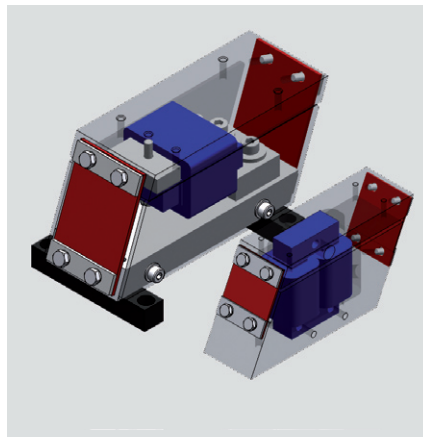

Color scheme of the individual components:

- Magnetic unit
- Spring package

## Technical data

Device type	HF1	HF10
Magnet type	RM30	RM30/E2
Magnet voltage	230 V/ 50 Hz	230 V/ 50 Hz
Air gap [mm]	0.3	1
Net weight [kg]	0.6	1.5
Rail weight [kg]	0.7	1.5
Max. current consumption [A]	0.16	0.16
Power consumption [VA]	37	37
Oscillation frequency [Hz]	50	50
Max. set-up length [mm]	350	350
Protection class in accordance with DIN EN 60529	IP 52	IP 52
Article no.	1-000005	1-000006

## Dimensions

Device type	Dimension [mm]											
	A	B	C	D	E	G	H	K	L	M	N	O
HF1	80	55	20	103	30	18	50	M3	M4	7	60	10
HF10	110	90	10	132	50	35	72	M4	Km4	20	65	32

### Technical drawing

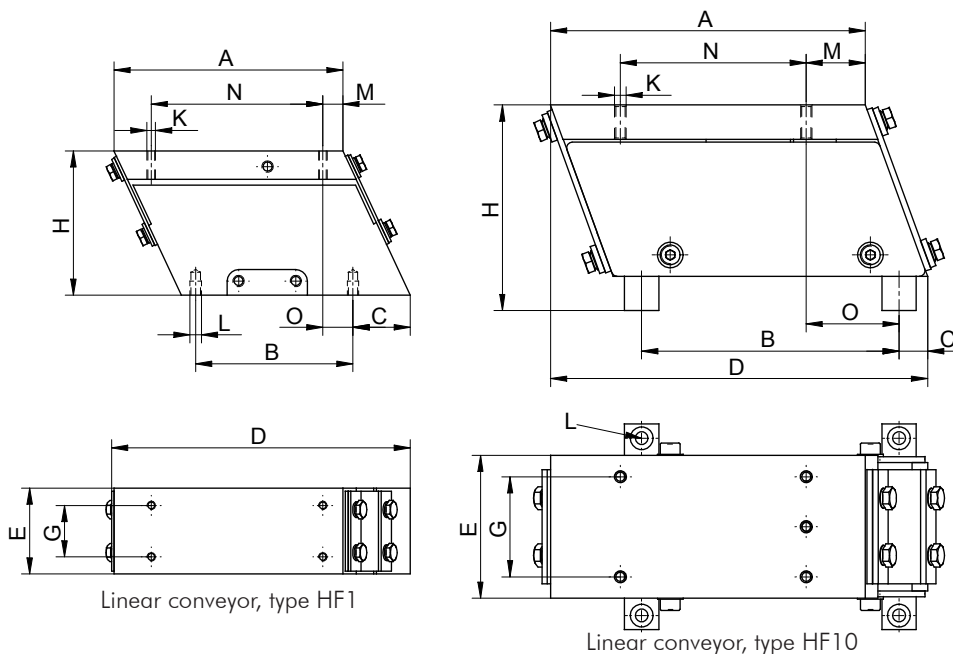

## Accessories

Designation	Description	Article no.
<b>Control unit FAR-1</b>	230 V/ 50 Hz, for linear and bowl feeders, phase-controllable	2-008185
<b>Control unit FAR-S-1</b>	230 V/ 50 Hz, for linear and bowl feeders, phase-controllable, with input for a signal for accumulation shut-down	2-008186
<b>Control unit FARR-S-1</b>	230 V/ 50 Hz, combination of FAR-1 and FAR-S-1	2-008187
<b>Control unit FUR-1</b>	230 V/ 50 Hz, purpose-built frequency converter for vibratory feeders	2-007872
<b>Control unit FUR-S-1</b>	230 V/ 50 Hz, purpose-built frequency converter for vibratory feeders, with input for a signal for accumulation shut-down	2-007897
<b>Stand for HF</b>	Height-adjustable stand with screw-on plate	1-000165
<b>Forked light barrier GL</b>	Fork width 10, 20, 30, 50, 80, 120 mm, without cable	2-001221